

---

**Q1051 - Bahij Abou Mrad/ 03623409/ Fassouh street**

Rony Chiha  
4-8 Harley Crescent  
Condell Park  
NSW 2200  
P: +96170619421 M: +96171727274

**Quote Number: Q1051**  
Quote Valid for 30 days  
Building Type: Residential  
Quote Date: 1/09/2020

---

*Achrafieh, Beirut Mount Lebanon Governorate*

This apartment has been damaged by "Beirut Explosion" on the 4th of August 2020. Steps of Hope in collaboration with A-Tech Australia took the initiative to help in the renovation of damaged houses, to get people back to their homes before winter comes.

Apartment damages survey:

- The job requires a technician with his workers. ET: 6 hours for installation.
- An aluminum panel is destroyed.
- 2 glass panels are shattered.
- A carpenter is needed for the assessment of wood damage and take measurements for the glass with wood frames.
- Also, a concrete technician is needed to fix the ceiling where holes are available in some places.
- This must be done as soon as possible due to the presence of water tanks above.

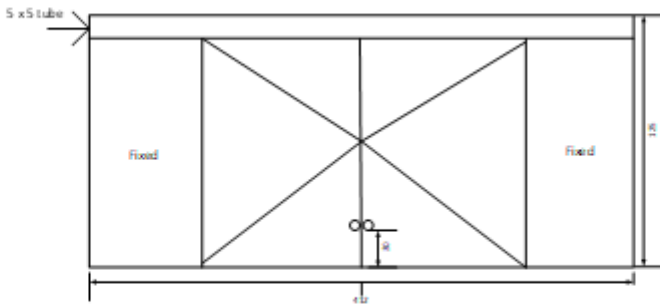

Specifications and Inclusions

Description	Dimensions (cm)	Quantity	Notes
Fixed panel			Aluminum mate black. Glass 6 mm, white. Windows with hinges
Glass	144.4 x 63.7	1	4 mm, white

**Q1051 - Bahij Abou Mrad/ 03623409/ Fassouh street**  
**Estimate**

**Customer:**

Rony Chiha  
4-8 Harley Crescent  
Condell Park  
NSW 2200  
Ph: +96170619421  
Email: [help@sohope.org.au](mailto:help@sohope.org.au)

**Estimate Details:**

Net Total: \$1,094.00  
Markup: \$0.00 (0%)  
Tax: \$0.00  
**Estimate Total: \$1,094.00**  
Building Type: Residential  
Date Prepared: 1/09/2020

Cost Items				
Code	Description	Units / UOM	Unit Cost	Total
<b>1</b>	<b>Glass</b>			<b>\$34.00</b>
1.1	4mm White	2.000	\$17.00	\$34.00
<b>2</b>	<b>Materials</b>			<b>\$900.00</b>
2.1	Aluminium Window	9.000 m2	\$100.00	\$900.00
	Aluminium Window	9.000	\$100.00	
<b>3</b>	<b>Labor</b>			<b>\$160.00</b>
3.1	Professional Installer	1.000 Day	\$55.00	\$55.00
	Professional Installer	1.000 Day	\$55.00	
3.2	Second Installer	1.000 Day	\$25.00	\$25.00
	Second Installer	1.000 Day	\$25.00	
3.3	concrete work + materials	1.000 Day	\$80.00	\$80.00

Net Total: \$1,094.00  
Markup: \$0.00  
Tax: \$0.00  
**Estimate Total: \$1,094.00**

